

# VCS3(mk2) QUAD MIDI-CV INTERFACE

VCS3 (mk2)

DK1/2 Keyboard

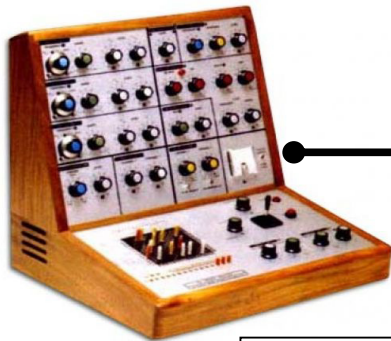

Cable to rear of VCS3 with 8 pin Male plug

Cable to rear of the Dk1 or DK2 Keyboard with 8 pin female plug

Midi Start Stop output

Midi clock output

Socket for special 4-way EMS matrix pin cable carrying CV1-CV4

Midi Learn Switch Normally OFF

Midi activity LED

MIDI INPUT

Toggle switches for changing the range of CV1-CV3 to maximum of either 0.32V/Oct or 1V/Oct

CV1-CV3 Scaling Potentiometers

Gate trigger Source KS or DK Keyboard G1-G4 are midi gates 1-4

Gate LEDs. These light when gate1 or gate2 are triggered by MIDI

Toggle switches to switch between keyboard (KS or DK) control or Midi-CV control

Inverts CV3 voltage +ve -> -ve

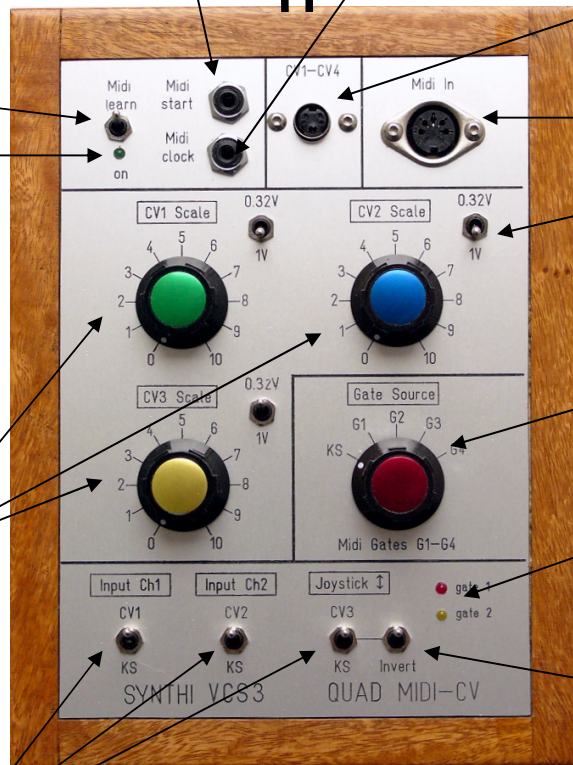

VCS3 (mk2) QUAD MIDI-CV

## Instructions on using the VCS3(mk2) Quad Midi-CV Interface

This is a **Quad Midi-CV** unit designed to be used with an EMS VCS3(mk2), either with or without an EMS Dk1/2 keyboard or an EMS external Touch Keyboard Sequencer (KS). It is based around Marc Bareille's fantastic 3-channel micro-controller based Midi-CV converter called the 'MCV876' (which Marc has kindly allowed me to incorporate in the modules)

See details of Marc's unit and all its many features at his website:-

<http://m.bareille.free.fr/mcv876/mcv876.html>

The latest units I ship have the most recent firmware (v3.06 as of October 2010) for the Pic18F2320 microcontroller which has faster better performance than the older models (based on Pic16F876 microcontrollers).

### Before Power On

With the VCS3 powered off, plug in the two grey cables with the 8 way 'Jones' plugs at each end. The male Jones plug to the rear of the VCS3 'keyboard' socket, and the female to the DK1/2 keyboard (if you have one). The Quad Midi CV unit allows independent switching between a connected DK/KS keyboard and midi control, through front panel toggle switches. Switch on the VCS3. You will see the green midi activity led (top left) flash a few times to indicate all is well.

The midi-cv board in the Quad Midi is powered by tapping off the +12V/-9V from the VCS3 (via the Jones plug cables) but only a small current is drawn so that normal operation of the VCS3(mk2) is unaffected.

**PLEASE NOTE FOR A VCS3 (mk1) YOU SHOULD USE THE SPECIALLY DESIGNED QUAD MIDI CV UNIT** made for the mk1 and its weaker internal psu.

N.B. The toggle switch at top left IS NOT A POWER ON/OFF SWITCH! It is the Midi learn switch (discussed below) and it should always be kept in the off (up) position in normal use.

The Quad Midi-CV unit has no on/off power switch. It is powered on/off when the VCS3 is switched on/off.

### The Midi Activity Led (green)

This is a multi-purpose led! The led blinks a few times at power on. Then the led will monitor all incoming recognised MIDI status bytes. The led also blink 3 long blinks if the interface receives the "Write To Flash" sysex message. When this message is received, all MCV876 parameters are written into the flash RAM. So the MCV876 can recall a setup even after a power off. When the interface is in MIDI Learn mode, the led stays on, until a MIDI message has been received and learned by the interface. In '**mono**' play mode (see play modes description below) the mid activity led flashes when midi notes are received. In other play modes it remains off when midi notes are sent..this is simply to speed up the mid->cv conversion in **polyphonic** and **multi** play modes where every bit of processing speed is 'squeezed' out of the microcontroller.

## The "MIDI learn" switch

To place the unit in midi learn mode toggle the midi learn switch on then off (down and back up). The midi activity led stays on until a MIDI message has been received and learned by the interface. The led will blink 3 long blinks if the interface receives the "Write To Flash" sysex message and will then automatically go out of midi learn mode to midi play mode.

If you wish to come out of midi learn mode without sending any new configuration data just toggle the midi learn switch down and up once more. Then the led will switch off and the unit is in the standard play mode.

**NB: the normal position for the midi learn toggle switch is in the 'up' position.**

### Here is how Midi learn works:

When you toggle the Midi Learn switch down then back up the midi activity led stays on and the MCV876 is in **Learn Mode** waiting to receive a Midi message containing Midi channel information. When a message arrives ( you play a note on the master keyboard for example) , the Midi channel number is extracted, compared to the actual interface Midi channel and set to this new value if different. If the Midi channel of the message is identical to the one configured into the interface, and if the message received is a Midi note ON message, the interface extracts the Midi number of the note played and sets this value as the reference (base or lowest ) note. This allows transpose of the MCV876 to any note on the keyboard. The reference note is the Lowest note the interface can play ( digital zero).

Using the small Windows configuration programme available from Marc's website you can configure the unit to **any of the available play modes** mode as you desire.

### V3.06 Firmware and different Play Modes

The Quad Midi-CV unit can be configured in these different playmodes using the windows configuration programme (version 3) which is available from <http://m.bareille.free.fr/mcv876/mcv876.html>

<b>Mono</b>	<ul style="list-style-type: none"><li>• CV1-Gate1 assigned to Note On/Off messages</li><li>• CV2, CV3,CV4* are assignable to controllers, velocity or PitchBend..</li><li>• Gates 2,3,4 are assignable to controllers.</li><li>• One channel recognition</li></ul>
<b>Multi2</b>	<ul style="list-style-type: none"><li>• CV1/Gate1 and CV2/Gate2 are on channel N - CV1 assignable to MIDI notes</li><li>• CV3/Gate3 and CV/Gate4 are on channel N+1 - CV4* assignable to MIDI notes</li></ul>
<b>Multi4</b>	<ul style="list-style-type: none"><li>• CV1 to CV4*and Gate1 to 4 are respectively on channels N to N+4</li><li>• CVs or gates can be assigned to MIDI notes or controllers independently.</li></ul>
<b>Poly2</b>	<ul style="list-style-type: none"><li>• CV1 +Gate1 and CV2+Gate2 are assigned to Note On/Off messages</li><li>• CV3 and CV4* are assignable to controllers, velocity or PitchBend..</li></ul>
<b>Poly4</b>	<ul style="list-style-type: none"><li>• CV1 to CV4* and Gate1 to 4 are assigned to Note On/Off message</li></ul>

\*note CV4 is only available on the Quad Midi-CV units.

## Triggering the VCS3 Envelope Shaper

The unit has Envelope Shaper (ES) trigger assignable to either keyboard (DK1 or DK2 if present) or any of the 4 gates (gate1-gate4) via a front panel rotary switch. How many of the 4 gates are available depends on the mode used (see above). Eg in **Poly2** mode, only 2 gates are available (gate1 and gate2). In **poly 4** mode or **Controller** mode, all 4 gates are available to trigger the ES.

**Red** and **yellow** panel LED's light when midi Gate 1 and/or Gate2 are triggered.

Gate 5 and gate 6 outputs are via jack sockets and offer Midi start/Stop and Midi clock signals for interfacing and synchronizing with other external midi devices.

## Using the front panel CV Scaling Potentiometers

CV1-CV3 can be scaled using the 3 front panel potentiometer knobs. These allow different response to midi generated control voltages. Of particular importance is the fact that EMS Synthi oscillators use **0.32V/Octave** standard **NOT** 1V/Octave as on most other synths. For pitch CV1 it is necessary to switch the toggle switch to the 0.32V/Oct setting and scale knob set to maximum value 10. This will produce correct chromatic scales on Osc1 and Osc2. For CV2 and CV3 you can either use 0.32V or 1V/Oct setting as you wish for different responses.

The 1V/Oct option is useful if a CV channel is being used as a modulation source rather than give pitch control of a synthi Oscillator. Also if your Synthi oscillators 1 and/or 2 are not exactly scaled to 0.32V/Oct.. use the 1V setting and adjust the scaling pots until you get proper chromatic pitches.

## NEW FEATURE FOR 2010: precision multi-turn trimmers for fine tuning of 0.32V/Oct scaling of CV1-CV3.

On the rear of all Midi-CV units produced form Nov 2010 onwards, you will find 3 multi-turn trimmers. These are adjusted by inserting a small flat head screwdriver.

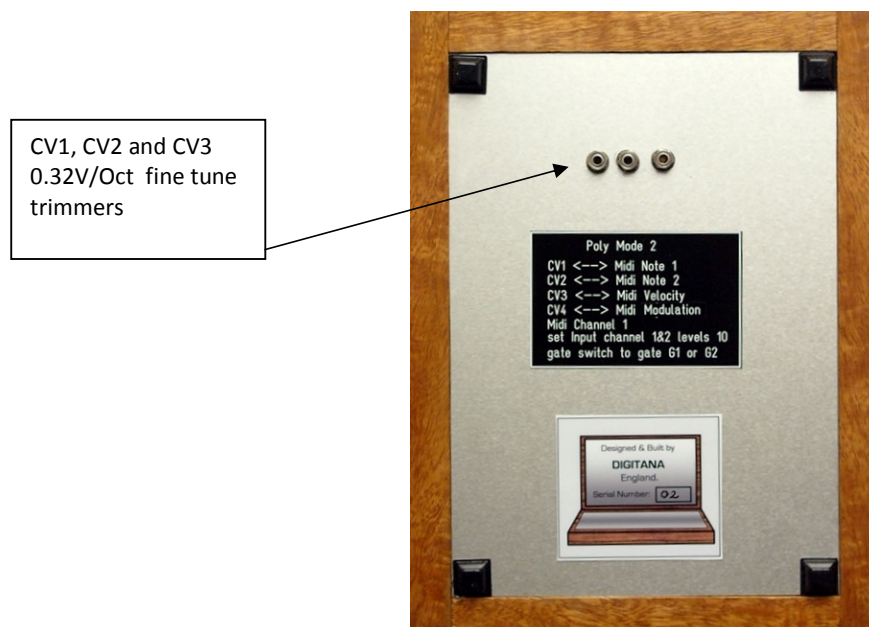

The purpose of these trimmers is that on many VCS3's, Osc1 and Osc2 scaling is not precisely 0.32V/Oct (unless its just been serviced). This results in out of tune /non-chromatic pitch scaling even if pitch cv at 0.32V/Oct is used to control Osc1/2 frequency. These trimmers allow you to get around this problem.

By default the trimmers are adjusted so that when CV1-CV3 pots are set at 10 on the front of the unit AND the 3 toggle switches are set to 0.32V/Oct, then pitch CV1-CV3 are scaled precisely at 0.32V/Oct.

If you find that your VCS3 sounds out of tune when you patch eg CV1 to Osc1 and CV2 to Osc2 freq control using matrix patch pins then do the following calibration. In what follows assumes the play mode of the unit is **Poly2**.

### Osc1/CV1

#### Make sure the VCS3 is warmed up first (at least 15mins)

Set Input ch1 pot on the VCS3 to max 10 and Osc1 frequency to some suitable value. Set up the following patch:

	SIGNALS								CONTROLS							
	output ch 1	output ch 2	envelope	ring mod	reverb	filter	osc. freq.	decay	filter freq	reverb mix	out-put ch level					
				A B			1 2 3				1 2					
output ch 1																1
output ch 2																2
oscillator 1	●															3
oscillator 2																4
oscillator 3																5
noise																6
input ch																7
	1															8
	2															9
filter																10
trapezoid																11
env. signal																12
ring mod																13
reverb																14
stick																15
																16

Set the CV1 scale pot to 10 on the Quad Midi-CV Unit and the toggle switch to 0.32V/Oct range.

Set the lower toggle switch to the CV1 setting and the gate setting to G1. Plug in a Midi Keyboard or software sequencer play a sequence of keys/notes at different octaves. If notes sound flat/sharp...make small adjustments to the **first** of the rear trimmers with a small screwdriver. You should hear the pitches of the notes played change. Doing this you can trim the 0.32V/Oct setting of CV1 to match the scaling of VCS3 Osc1 so it tracks chromatically over several octaves.

## Osc2/CV2

Apply the same procedure as above to CV2 and Osc2. The patch will now be as above but the black pin connects Osc2 out to Output ch1 and the red precision pin connects Input Ch2 to Osc2 frequency control.

**Make sure Input ch2 level pot is set at 10 on the VCS3.**

Set the CV2 scale pot to 10 on the Quad Midi-CV Unit and the toggle switch to 0.32V/Oct range.

Set the lower toggle switch to the CV2 setting and the gate setting to G2. Plug in a Midi Keyboard or software sequencer play a sequence of keys/notes at different octaves. This time to trigger G2 and midi note 2 pitch CV (which is CV2) you need to hit 2 keys at the same time. In poly2 mode ..the unit is duophonic so that when 2 keys are struck at once it assigns lower note to CV1/Gate1 and upper note to CV2/Gate 2. We want to trim the CV2 0.32V/Oct so you need to hit 2 keys (eg 2 keys next to each other on the midi keyboard is easiest) to trigger gate G2 and CV2. If you hit just one key you will only trigger G1 and only Cv1 will change as you play different single notes.

Now whilst playing these two keys transpose the midi keyboard up an octave or down and octave. If the notes heard through the VCS3 sound flat/sharp...make small adjustments to the **second** of the rear trimmers with a small screwdriver. You should hear the pitches of the notes played change. Doing this you can trim the 0.32V/Oct setting of CV2 to match the scaling of VCS3 Osc2 so it tracks chromatically over several octaves.

The fine tuning of CV3 scaling is less critical unless you intend on using CV3 to act as pitch CV for controlling Osc3 in the audio range. You will need to put the unit in **Poly4** play mode if you want to use this option because In this mode Cv1-Cv4 correspond to pitches of Midi notes 1-4. For changing play modes on the unit see later on in this guide. Note Osc3 in the VCS3 is not (by design) tacking at 0.32V/Oct but at 0.26V/Oct (!) so you will need to adjust the **third** trimmer on the rear of the unit rather more than for CV1 and CV2 to get the scaling down to 0.26V/Oct. Other than this the procedure is as above but the patch should now take Osc3 to Output Ch1 and CV3 to Osc3 freq. control. which is achieved by inserting a red precision pin to connect row 16 (stick vertical CV) to Osc3 freq control input and also making sure you have rotated and 'clicked' off the stick vertical scaling pot on the VCS3. This turns row 16 into the third input channel where CV3 emerges.

Switch the gate selection control to G3 and then hit 3 simultaneous keys on your midi keyboard. This will generate CV1-CV3 pitch CV's and trigger G1-G3 (only G1 and G2 have Led's that light ). Apply transpose to the 3 keys you are simultaneously hitting to test chromatic scaling of Osc3 and adjust the third trimmer as necessary.

Finally, You will have to have the inverter toggle switch in the on 'invert' position. Otherwise you will find Osc3 plays 'backwards'..ie playing a higher key on the keyboard (hence a larger positive CV3 voltage) generates a lower note (and visa-versa). The reason is a bit technical but it's to do with the fact that all 3 Synthi Oscillators actually track using a -ve CV (NOT Positive CV which is the norm for most other synths). Since Input Ch1/2 invert voltages fed into them (they are inverting amplifiers) positive midi-generated CV1 and CV2 get inverted to -ve CV by them. But row 16 (the third Input channel) does not invert..hence the reason why I designed the unit to allow inverting of CV3.

## Lower Toggle Switches Function

Lower toggle switches allow independent switching of DK/KS control or Midi-CV control of each of the 3 independent CV input channels of the VCS3(mk2) matrix (Input Ch1, Input Ch2, and row 16 of the matrix).

As mentioned above, there is also the option to invert CV3 or the DK/KS CV source into row16 of the matrix via another toggle switch..again adding to the creative possibilities.

Any pattern based or multi-tracking software/hardware sequencer or Midi keyboard will work with the unit. Software sequencers (eg those used in Cubase etc) allow the drawing of 'envelope shapes' for Midi continuous controller messages. These will then create dynamic envelopes (eg for velocity, pitchbend, modulation wheel etc.) that can be used for any/all of CV1-CV4.

## The Special 4 EMS pin Cable

CV1-CV4 are also available via the special cable that connects to the unit with 4 EMS patch pins on one end and mini-din plug on the other. The CV is connected to the tip of the pins only and is designed to be able to inject CV1-CV4 into any of the Synthesizer control inputs (ie matrix columns). Inserting these pins has **no** affect on the rows and they do NOT route signals from the rows into the matrix columns, as ordinary pins do. Thus in injecting CV1-CV4 into any column on the matrix, it does not matter which row you choose to insert them..only the column matters.

The pins are colour coded with **green**, **blue** and **yellow** corresponding to CV1-CV3 and **black** to CV4.

The purpose of this cable is that CV1-Cv4 can be used even when control of the synthesizer input channels is via the DK/KS (via the toggle switches). So its possible eg to use the VCS3 'normally' with the DK keyboard or KS etc and still have CV1-CV4 available via the matrix pin cable to add dynamic envelopes etc created via midi for e.g. filter control, Reverb mix, output channel level envelopes etc..to create very complex patches.

## Creating Patches Using the Unit

***It's best to have the Input Ch1 and Input Ch2 pots on the VCS3 set to their maximum value 10.***

CV1 enters the AKS matrix via Input ch1 and CV2 via input ch2. Locate the joystick vertical control scaling Pot on the AKS lower panel and turn it to the 'seq' setting (make sure you hear the 'click' as the pot switch turns off). Then row 16 of the matrix (marked Joystick vertical control) carries CV3 instead and the joystick vertical control is disabled.

Remember, CV4 is only available via the black pin of the special EMS pin cable discussed above.

The CV1-CV4 sources are thus :-

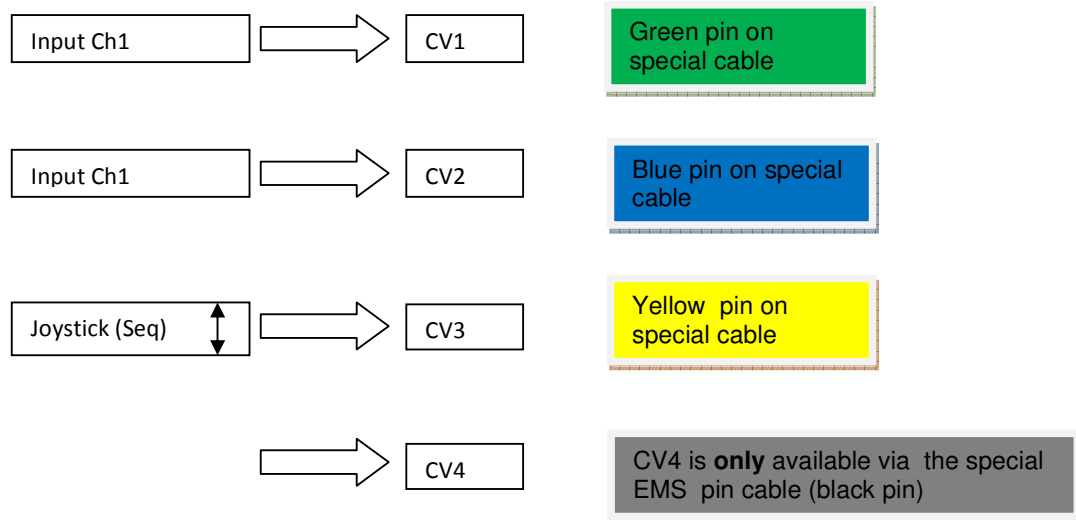

Then use patch pins to simply patch CV1, CV2 or CV3 to any desired input. E.g. in **PolyMode2** for duophonic sequencer use, CV1 (which is the pitch CV1 in polymode2 ) can be patched to osc 1 and CV2 (pitch CV2 in polymode2) patched to osc 2 frequency control. So insert pins at **I8** and **J9** on the matrix. Row 16 (Joystick vertical control) can be used e.g. as modulation CV connected to filter cutoff, reverb mix, Output channel levels etc by inserting appropriate pins.

### Secret trick of the Synthi: How to invert a signal without mods!

The various synthi control inputs (marked 'control inputs' on the matrix ) respond differently to positive/negative control voltages. So for example the trapezoid envelope is a positive voltage which can be applied to filter frequency, oscillator pitch, envelope decay etc. But its useful to be able to invert the trapezoid and make it negative as the response is interesting and different.

People have 'mods' done to their Synthi that allow inversion of signals whilst being routed, by a special pin cable and additional circuits.

But if you dont mind sacrificing one of the 2 input channels, there is a way of achieving this WITHOUT any mods!

The reason I mention this inversion trick is that it can also be applied to any of the midi generated CV1-CV4 from the Quad unit..so it adds even more to the creativity of the unit.

Here is how you do it. If you patch any signal into the meter column it immediately becomes available to the Scope socket. What's important is that the signal has gone through an inverting amplifier circuit that drives the meter before arriving at the Scope output.. Thus the signal that appears on the Scope output is the inverted version of the signal patched into the meter column.

If you now connect the Scope jack to eg the High Level Input Ch1 jack (or it could be Ch2) via a standard jack cable, the inverted signal you sent into the meter will appear to the matrix via Input ch1 row! What's more you can control the level of the inverted signal via the Input Ch1 level pot. So you have a level controlled inverter for 'free'.

To invert any of CV1-CV4 this way..simply insert one of the 4 pins from the special cable into the meter column (doesn't matter which row you choose because as mentioned earlier these pins only have connection to their tips) and patch Scope to Input Ch1.

You'll find inverting and scaling of CV4 particularly useful as there is no front panel scaling pot for it on the midi-cv unit (not enough room!) unlike CV1-CV3.

## Using the Windows Configuration Program to change Play Modes

The different play modes of the Quad Midi-CV unit are accessed via sysex messages sent to the unit through a midi cable connected to eg a USB or other midi interface running on a Windows PC/laptop. The programme (and any future updates) is available from Marc Bareille's website:-

<http://m.bareille.free.fr/mcv876/mcv876.html>

**Make sure you download version 3** of the programme.

On running the programme the following screen appears:-

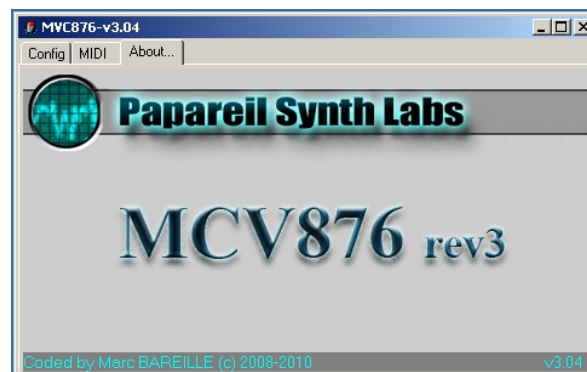

There are just 3 main tabs. Click on 'Midi' tab to setup the midi out port on your PC :-

Make sure this corresponds to the midi out you are using to connect to the Quad Midi CV

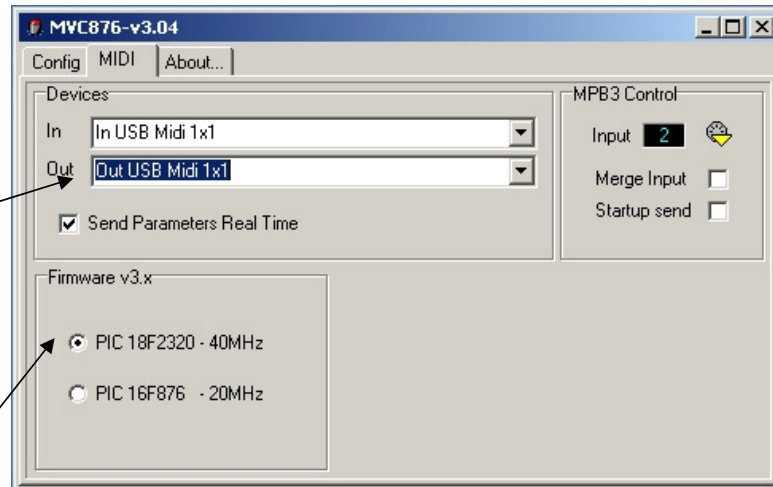

**Must** choose this option

In the above a 1x1 Midi Sport USB midi interface is being used.

**It is very important you tick the 'PIC 18F2320 -40MHz ' button..as all my midi cv units use this processor and firmware v 3.x**

Also click the 'send parameters in real time' button as this speeds up the process of changing play modes. There are other options to the right concerning midi inputs that you don't need worry about for basic operation.

Now click the main Config tab which is where you can choose the different play modes :-

The screenshot shows the MVC876-v3.04 software interface. It features a menu bar with 'Config', 'MIDI', and 'About...'. Below the menu bar are icons for file operations and a 'write to Flash' button. The main interface is divided into several sections:

- Master Mode:** Includes a 'Mode' dropdown set to 'Poly2', a 'Channel' dropdown set to '1', and a 'NoteRef' dropdown set to 'C-2'.
- MIDI Clock:** Includes a 'Divide by' input set to '0' and a 'Div by N' dropdown.
- Triggers:** Includes 'Duration' (set to 1), 'Thresh.' (set to 0), and a 'Gate 5' checkbox.
- DACs (Digital to Analogue Converters):** A table with 4 rows and 5 columns. The first column is 'Cc', and the last column is 'Trig'. The rows are:
 

Cc		PB	VL	5V	Trig
<input type="checkbox"/>	Bank Select	<input type="checkbox"/>	<input type="checkbox"/>	<input type="checkbox"/>	<input type="checkbox"/>
<input type="checkbox"/>	Modulation Wheel (coarse)	<input type="checkbox"/>	<input type="checkbox"/>	<input type="checkbox"/>	<input type="checkbox"/>
<input type="checkbox"/>	Modulation Wheel (coarse)	<input checked="" type="checkbox"/>	<input type="checkbox"/>	<input type="checkbox"/>	<input type="checkbox"/>
<input checked="" type="checkbox"/>	Volume (coarse)	<input type="checkbox"/>	<input type="checkbox"/>	<input checked="" type="checkbox"/>	<input type="checkbox"/>
- Gate:** A table with 4 rows and 2 columns. The first column is 'Bank Select' and the second is 'Trig'.
 

Bank Select	Trig
<input type="checkbox"/>	<input type="checkbox"/>
<input type="checkbox"/>	<input type="checkbox"/>
Controler n° 20	<input type="checkbox"/>
Controler n° 3	<input type="checkbox"/>

Callout boxes provide the following information:

- 'click to send sysex message directly to the Quad Midi-CV Unit and change the play mode' (points to the sysex icon)
- 'write to Flash' button. click to save the chosen play mode into the flash memory of the Quad Midi -CV (points to the flash icon)
- 'presets' where you can save your favourite play modes settings for quick change (points to the preset icons)
- Play mode choice (points to the Mode dropdown)
- Midi Chan. (points to the Channel dropdown)
- Lowest midi note Quad Unit responds to (points to the NoteRef dropdown)
- 4 Digital to analogue converters (DAC's) corresponding to CV1-CV4 \* (points to the DAC table)
- 'PB'=pitch bend (points to the PB column in the DAC table)
- 'VL'=Note Velocity (points to the VL column in the DAC table)
- limits maximum CV to +5V (points to the 5V column in the DAC table)

\* Note the labelling of the 4 DAC's is DAC0-DAC3 (as opposed to DAC1-DAC4 ) in the configuration program.

You just have to remember that DAC0-DAC3 correspond to CV1-CV4 as used in this guide. Similarly you will notice that Gate1-Gate4 are labelled as 'Gate0-Gate3' in the program.

In the above example, if the send to flash button is clicked the Quad Unit would be set to **Poly2** play mode. This means CV1 corresponds to Midi note 1 and gate G1 is triggered by Midi note 1 on message; CV2 corresponds to Midi note 2 and Gate 2 is triggered when Midi note 2 on

message is received. Meanwhile CV3 is set to Pitch Bend (green box ) and finally CV4 corresponds to the Midi Volume (Coarse). In addition the '+5V' option is also checked, which means the maximum swing of CV4 = +5v. So a Midi Volume value of 0 gives 0V on CV4 whereas a Midi Volume value of 128 sets CV4 to +5V.

Limiting the maximum swing to +5V can be useful and give better resolution/response depending on what control destination on the VCS3 you are routing the CV.

Notice in this example all the text in the first 3 DAC boxes is greyed and CC boxes are 'unchecked'. This is because we have used up 3 DAC assignments. Two are used for Midi note 1 and Midi note 2 CV, the third on Pitch Bend CV. This only leaves CV4 (DAC3) which to freely assign a Midi CC. Similarly looking at the Gate CC's assigned. G1 and G2 are greyed out because they are automatically assigned to Midi note1 and note 2 'on' events. This leaves G3 and G4 assignable to a Midi CC.

Here is another example which sets the Quad Unit again to **Mono** play mode.

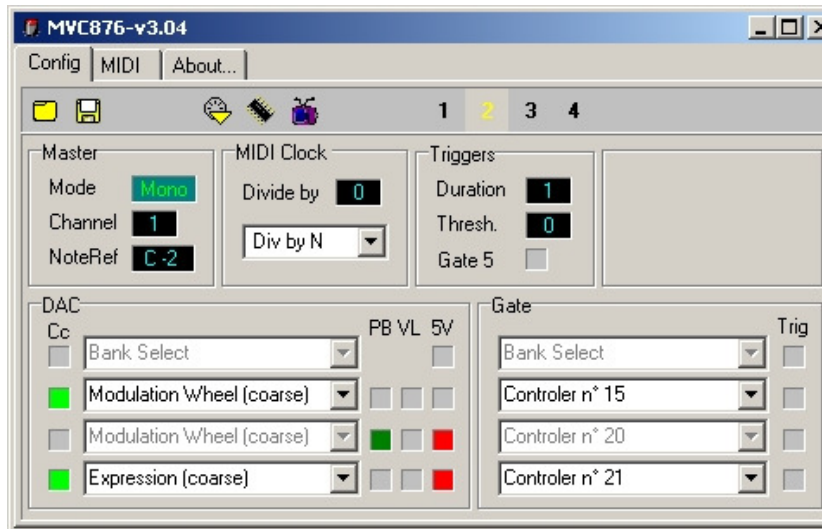

Thus CV1 is automatically assigned to midi note1 value. This leaves CV2-CV4 freely assignable to PB, VL, or a CC. In the example CV2 is assigned to Modulation Wheel (Coarse) CC, CV3 to Pitch Bend and CV4 to Expression (Course) CC. In addition maximum swing of CV3 and CV4 is limited to +5v.

G1 is automatically assigned to Midi note 1 on message. But G2-G4 can be freely assigned to Midi CC's. In the example G2-G4 are assigned to controllers 15, 20 and 21.

Finally, if you click either the 'send to Midi' or 'Write to Flash' buttons you will see the Midi activity led flash briefly as the processor is updated. Writing to Flash means the unit will remember the play mode change even after power down.

## Velocity Assignment in Play Modes

In **mono mode** velocity assignment is straightforward..just tick the 'VL' box to assign velocity CV to any of CV2-CV4. On the VCS3 you would want to patch this velocity CV to control the either or both of the output channel levels (last two columns in the matrix). These channels respond differently to positive and negative CV..so its advisable to assign velocity to CV3 as you then have the option on the quad unit to not only scale but also invert this CV. You can then experiment to find interesting velocity 'curves'.

In **poly mode 2** its best to again assign velocity to CV3 by clicking the 'VL' box. If you choose CV4 ..the problem is this is only available to the synthi via the black pin cable and thus you can only control the level of output ch1 or output ch2 by inserting the pin but not both at the same time.

Obviously in **poly mode 4** you have no options to assign note velocity or any other midi parameter to CV as all 4 CV channels are taken up with midi notes.

In experimenting with velocity curves on the VCS3 you will also find it useful to adjust the main output channel level pots as the setting of these also affects the overall velocity response of the output channels.